

1. PRODUCT NAME

POLYKEN® Foilastic™ 626-35
Flashing Tape

POLYKEN® Shadowlastic 627-
35 Flashing Tape

Nashua® 626-20 Optiflash
F20

Nashua® 627-20 Optiflash
B20

Nashua® Contour 697-40

2. MANUFACTURER

Berry Plastics Tapes and
Coatings Division

25 Forge Parkway

Franklin, MA 02038

Phone: 1-800-248-7659

Fax: 1-800-328-4822

Website: www.berryplastics.com

3. PRODUCT DESCRIPTION

Basic Use: Polyken® and Nashua® and 626 foil-faced and 627 polyethylene-faced butyl rubber-based adhesive-coated flashing tapes are used to prevent moisture and water entry into buildings.

Polyken® and Nashua® 626 and 627 are primarily used for perimeter flashings around window, door, and skylight openings, and for other general flashing uses including roofing applications.

Precautions and Limitations: Polyken® and Nashua® 626 and 627 can be applied directly to most building sub-strates e.g., plywood, galvanized sheet metal, asphalt-saturated building papers/felts.

For rough surfaces or textured materials, such as OSB, gypsum board, concrete, masonry and fiberglass-mat surface sheathing, it is recommended that a primer, i.e., Polyken® 1027, be used to promote adhesion between flashing tape and substrate.

Polyken® and Nashua® have an application temperature range of 20°F – 180°F and a service temperature range of -35°F – 200°F

Polyken® and Nashua® Flashing Tapes will withstand exposure to direct sunlight for extended periods. While the Polyken® Shadowlastic, Nashua® Optiflash B20 and Nashua® Contour will resist UV degradation for up to one year, the Polyken® Foilastic and Nashua® Optiflash F20 can be exposed to ultraviolet light indefinitely.

Polyken® and Nashua® 626 and 627 can become slippery when covered by moisture or frost.

Composition and Materials: Polyken® and Nashua® 626 and 627 Flashing Tapes are designed to be cold-applied, self-adhering flashings with strong and immediate adhesion to wood, metal, concrete and masonry surfaces. Both the polyethylene and foil facings with the butyl rubber-based adhesive combine to provide a tough, conformable moisture barrier.

Polyken® and Nashua® 626 and 627 flashing tapes exhibit excellent low temperature flexibility and adhesion properties and will not flow at elevated temperatures. Polyken® Foilastic and Shadowlastic have a non-moisture absorbent polyethylene release liner. Nashua® Contour, Optiflash F20 and Optiflash B20,

have a moisture stable poly-coated kraft release liner, both designed for easy release.

4. TECHNICAL DATA

Polyken® and Nashua® 626 and 627 Flashing Tapes conform to the physical properties as stated in Tables 1, 2, and 3.

Applicable Standards: Polyken® and Nashua® 626 and 627 Flashing Tapes meet the requirements of the following specifications:

Electronic SPEC-DATA®

SPEC-DATA® II

Sweets Architectural Catalog

MASTERSPEC Section 07650

Flexible Flashing.

5. INSTALLATION

Surface Preparation: Polyken® and Nashua® 626 and 627 Flashing Tapes are designed to be applied directly on plywood, metal, or masonry substrates. Remove any dust, dirt, nails or other objects from the substrate before applying the flashing to new construction.

Priming: Concrete or masonry surfaces can be primed with Polyken® #1027 Primer, following manufacturer's instructions. Refer to Table 4 for product information.

Priming, however, does increase the overall adhesion on steel and wood surfaces even though it is usually not necessary under normal circumstances.

Temperatures: Apply Polyken® and Nashua® 626 and 627

Flashing Tapes in fair weather at temperatures of 25°F or higher. The adhesive will not flow at elevated temperatures.

Flashing Application: Surfaces should be dry and free of dust, dirt or other foreign matter. For positive drainage flow begin flashing application at the low point of a wall or sloped roof deck. Overlaps should be a minimum of three inches. All membrane edges and overlaps should be hand rolled.

6. AVAILABILITY AND COST

Availability: Polyken® and Nashua® 626 and 627 Flashing Tapes are available from strategically located warehouses and from a network of distributors ensuring prompt delivery throughout the United States.

Cost: Polyken® and Nashua® 626 and 627 Flashing Tapes are competitively priced. Contact a local Polyken® or Nashua® representative for specific cost information.

7. WARRANTY

Polyken® and Nashua® Flashing Tapes are warranted to be free of defects in manufacturing. Contact Berry Plastics for specific information regarding the 12-year limited warranty.

8. MAINTENANCE

No maintenance is required for Polyken® and Nashua® 626 and 627 Flashing Tapes if the installation has been in accordance with the manufacturer's recommendations.

9. TECHNICAL SERVICES

Complete technical assistance is available.

10. FILING SYSTEMS

Electronic SPEC-DATA®
SPEC-DATA® II
Sweets Architectural Catalog
MASTERSPEC Section 07650

The ten-point Spec-Data® format has been reproduced from publications copyrighted by CSI, 1964, 1965, 1966, 1967, and used by permission of The Construction Specifications Institute, Alexandria, VA 22314.

**Table 1
Materials, Thickness and Weight**

Flashing Tape		Material			Thickness (mills.)		
Product Name	Product Code	Facing	Membrane Adhesive	Release Liner	Facer	Membrane Adhesive	Overall Total
Nashua OptiFlash F20	626-20	Alum. Foil	Butyl Rubber	Poly Coated Kraft Paper	2	17	19
Nashua OptiFlash B20	627-20	HDPE (Black)	Butyl Rubber	Poly Coated Kraft Paper	6	14	20
Nashua Contour	697-40	Cross Laminated HDPE (White)	Butyl Rubber	Poly Coated Kraft Paper	20	40	60
Polyken Foilastic	626-35	Alum. Foil	Butyl Rubber	LDPE (Blue)	2	33	35
Polyken Shadowlastic	627-35	HDPE (Black)	Butyl Rubber	LDPE (Blue)	6	29	35

Notes:

1. One mil thickness = 0.001 inches

**Table 2
Dimensions**

Flashing Tape	Roll Length (feet)	Tape Width (inches)
Nashua® Optiflash B20	100	4, 6, 9
Nashua® Optiflash B20	100	4, 6, 9
Polyken® Foilastic 626-35	50	2, 3, 4, 6, 9, 12
Polyken® Shadowlastic 627-35	50	6, 9, 12
Nashua® Contour 697-40	75	6, 8

Table 3: Physical Properties

Criteria		Flashing Tape				
Property	Test Method	Polyken®		Nashua®		
Product		Shadowlastic 627-35	Foilastic 626-35	OptiFlash B20 627-20	OptiFlash F20 626-20	Contour 697-40
Color (facer)		Black	Aluminum	Black	Aluminum	White
Thickness	ASTM D-3767 & ASTM D-1000	35 mils	35 mils	20 mils	20 mils	60 mils
Tensile Strength MD	ASTM D412-97	>*813 psi, 5602 kn/m ²	>*445 psi, 3066 kn/m ²	>*1371 psi, 9446 kn/m ²	>*800 psi, 5512 kn/m ²	>*295 psi, 2033 kn/m ²
Tensile Strength CD	ASTM D412-97	300 psi, 2411 kn/m ²	300 psi, 2411 kn/m ²	400 psi, 2756 kn/m ²	800 psi, 5512 kn/m ²	400 psi, 2756 kn/m ²
Elongation	ASTM D412-97	>180%	< 4%	>130%	<2.7%	>575%
Adhesion to Plywood	ASTM D903-93 ⁽¹⁾	141.3 oz/in 1.5 N/mm	196.4 oz/in 2.1 N/mm	62.7 oz/in 0.68 N/mm	96.0 oz/in 1.05 N/mm	96.4 oz/in 1.05 N/mm
Steel	PSTC-1	281.9 oz/in 3.1 N/mm	292.8 oz/in 3.2 N/mm	268.7 oz/in 2.9 N/mm	292.6 oz/in 3.2 N/mm	113.8 oz/in 1.2 N/mm
OSB	ASTM D903-93 ⁽¹⁾	125.3 oz/in 1.4 N/mm	139.3 oz/in 1.5 N/mm	64.2 oz/in 0.70 N/mm	76.5 oz/in 0.80 N/mm	100.6 oz/in 1.1 N/mm
Felt	ASTM D903-93 ⁽¹⁾	>9.4 lb/in 1.6 N/mm	176.6 oz/in 1.9 N/mm	68.4 oz/in 0.70N/mm	99.4 oz/in 1.1 N/mm	117.8 oz/in 1.3 N/mm
Housewrap	ASTM D903-93 ⁽¹⁾	221.9 oz/in 2.4 N/mm	243.8 oz/in 2.7 N/mm	210.2 oz/in 2.3 N/mm	232.1 oz/in 2.5 N/mm	>150.5 oz/in 1.6 N/mm
Unprimed Brick	ASTM D903-93 ⁽¹⁾	150.5 oz/in 1.6 N/mm	116.1 oz/in 1.3 N/mm	56.6 oz/in 0.60 N/mm	82.9 oz/in 0.90 N/mm	119.0 oz/in 1.3 N/mm
Extruded Vinyl	ASTM D903-93 ⁽¹⁾	237.0 oz/in 2.6 N/mm	238.8 oz/in 2.6 N/mm	162.2 oz/in 1.8 N/mm	201.0 oz/in 2.2 N/mm	139.8 oz/in 1.5 N/mm
Lap Adhesion (Adhesion to backing)	ASTM D903-93 ⁽¹⁾	200.0 oz/in 2.19 N/mm	200.0 Oz/in 2.19 N/mm	32.0 Oz/in 0.35 N/mm	16 oz/in 0.18 N/mm	
Pliability	ASTM D146-97 ⁽²⁾	No effect	No effect	No effect	No effect	No effect
Permeance	ASTM E96-94	<0.5 perm	<0.1 perm	<0.3 perm	<0.3 perm	
UV exposure resistance	AAMA 711-05	1 year	10 years	1 year	10 years	1 year
Installation Temp.	AAMA 711-05	20F-180F (1C-93C)	20F-180F (1C-93C)	20F-180F (1C-93C)	20F-180F (1C-93C)	20F-180F (1C-93C)
Service Temp.		-35F-200F (-37C - 93C)	-35F-200F (-37C - 93C)	-35F-200F (-37C - 93C)	-35F-200F (-37C - 93C)	-35F-200F (-37C - 93C)

Notes:

MD = Machine Direction

CD = Cross Direction

(1) ASTM D903-93 method was modified for a sample 24 hour adhesive contact period prior to testing

(2) ASTM D146-97 Pliability was determined after 24 hour conditioning at -40F and wrapping specimen around a 2" diameter mandrel

Table 4
Primers—Physical Properties

Criteria	Polyken® 1027	Nashua® 357
Base	Butyl based elastomers blended with polymeric resins	C-12 & C14 Isoalkanes polymers and resins
Solvent	V.M. and P Naptha	Hexane, Propane, Acetone & Dimethyl Ether
Total Solids	30% +/- 1%	15% +/- 1%
Weight	7.1 lbs/gal (0.86 kg/l)	23.8 oz/ 674 grams
Viscosity	Medium Syrup	not determined
Flash Point	40F (4C)	-104F/ -156C
Color	Black	White
Shelf Life	Excellent	One year
V.O.C.	4.9 lbs/gal (0.59 kg/l)	378 g/l
Application	Roller or Brush	Spray/Aerosol Can. Tape off area from overspray.
Coverage	4 sq. yds/gal (9.8m ² /l)	Varies

**Table 5
Sealant Adhesion**

		Location of Sealant (See Below)		
Type of Sealant	Adhesion	(1) Over Facing	(2) Along Seam	(3) Under Adhesive
Butyl	<51.0 oz/in	Yes	Yes	Yes
Hybrid	33.4 oz/in	Some	Some	Yes
Polyurethane	5.5 oz/in	Some	Some	Yes
Silicone	0.8 oz/in	No	Some	Yes

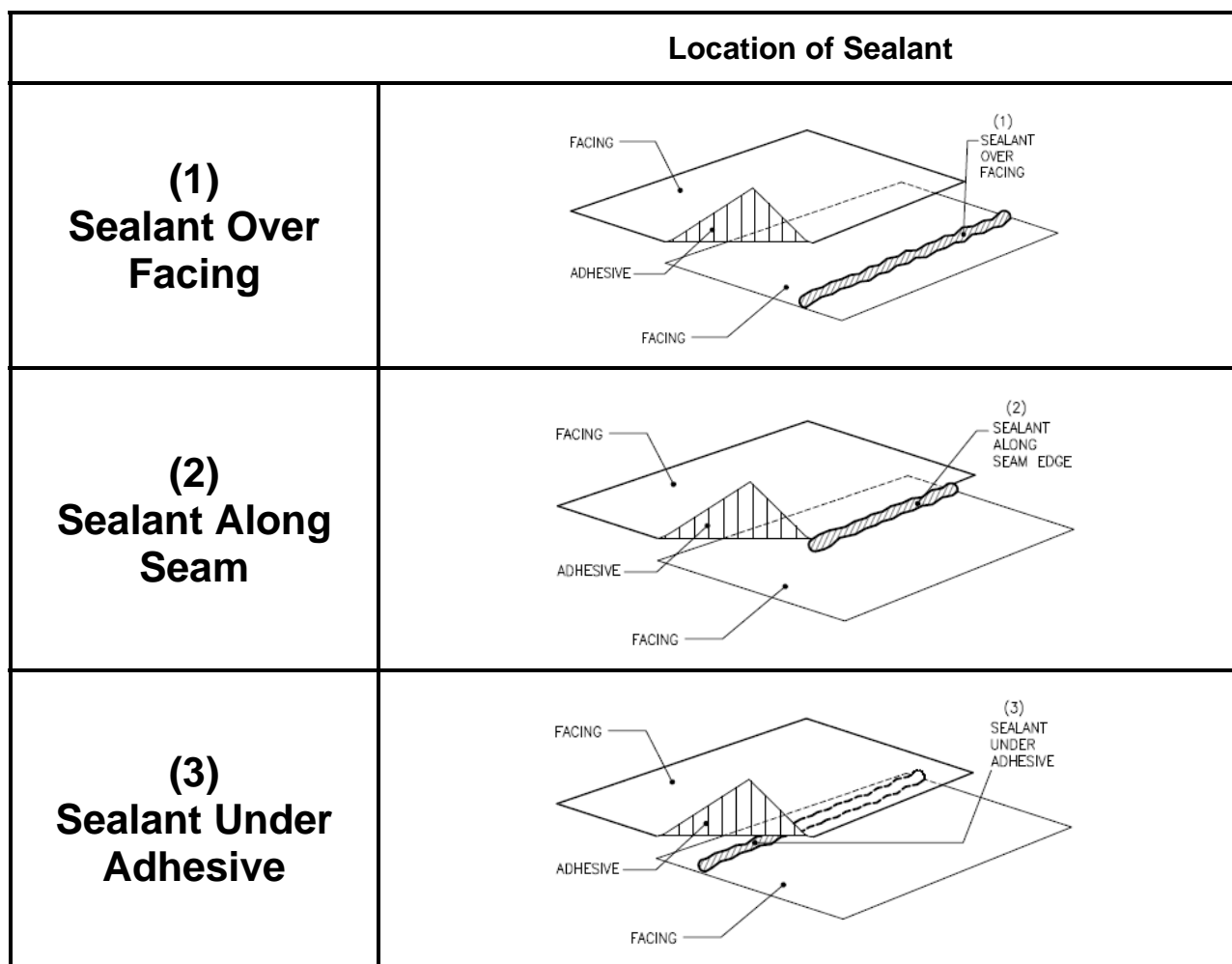

Table 6: Sealant Compatibility

Flashing Tape	Backing	Adhesive	side applied to	Sealant Name	Sealant Type	Visual Observation	Pass/ Fail	Exposure time @150F
n/a - control	LDPE film	none	backing	Dow Corning 795	Silicone	FI - unchanged, Sep	P	31
Sample A	2.5 mil PP	27.5 mil SBS A	backing	original color - white		FI, SLD, Sep	P	31
Sample A	2.5 mil PP	27.5 mil SBS A	adhesive			FI, MD, Sep, P, adh. Distorted	F	31
Sample B	14 mil PE	Butyl rubber	adhesive			FI, SLD, Sep	P	31
Sample C	14 mil PE	Butyl rubber	adhesive			FI, SLD, Sep	P	31
Sample D	6 mil PE	Butyl rubber	backing			FI, SLD, Sep	P	31
Sample D	6 mil PE	Butyl rubber	adhesive			FI, SLD, Sep	P	31
n/a - control	Si Rel. Paper	none	release	Vulkem 116	PU	FI, unchanged, Sep	P	31
Sample A	2.5 mil PP	27.5 mil SBS A	backing	original color - white		FI, SLD, Sep, P, adh. Flowed out	F	31
Sample A	2.5 mil PP	27.5 mil SBS A	adhesive			FI, HD, PB, HP, adh. Distorted	F	6
Sample B	14 mil PE	Butyl rubber	adhesive			FI, ND, PB	P	31
Sample C	14 mil PE	Butyl rubber	adhesive			FI, ND, PB	P	31
Sample D	6 mil PE	Butyl rubber	backing			FI, SD, Sep	P	31
Sample D	6 mil PE	Butyl rubber	adhesive			FI, SD, PB	P	31
n/a - control	Si Rel. Paper	none	release	Geocell 2300	TP Rubber	FI, unchanged, Sep	P	31
Sample A	2.5 mil PP	27.5 mil SBS A	backing	original color - clear, transparent		FI, MD, Sep	P	31
Sample A	2.5 mil PP	27.5 mil SBS A	adhesive			FI, MD, PB, MP, adh. Flowed	F	3
Sample B	14 mil PE	Butyl rubber	adhesive			FI, ND, PB	P	31
Sample C	14 mil PE	Butyl rubber	adhesive			FI, ND, PB	P	31
Sample D	6 mil PE	Butyl rubber	backing			FI, ND, Sep	P	31
Sample D	6 mil PE	Butyl rubber	adhesive			FI, ND, PB	P	31
n/a - control	Si Rel. Paper	none	release	Sikaflex 1a	PU	FI, unchanged, Sep	P	31
Sample A	2.5 mil PP	27.5 mil SBS A	backing	original color - white		FI, SD, Sep - falling off	F	31
Sample A	2.5 mil PP	27.5 mil SBS A	adhesive			FI, HD, PB, HP, adh. Distorted	F	3
Sample B	14 mil PE	Butyl rubber	adhesive			FI, ND, PB	P	31
Sample C	14 mil PE	Butyl rubber	adhesive			FI, SD, PB	P	31
Sample D	6 mil PE	Butyl rubber	backing			FI, SD, Sep	P	31
Sample D	6 mil PE	Butyl rubber	adhesive			FI, SD, PB	P	31
n/a - control	Si Rel. Paper	none	release	Geocell 3300	PU	FI, unchanged, Sep	P	31
Sample A	2.5 mil PP	27.5 mil SBS A	backing	original color - rust		FI, ND, Sep, HP, adh. Flowed out	F	31
Sample A	2.5 mil PP	27.5 mil SBS A	adhesive			FI, ND, fell off, HP, very distorted	F	3
Sample B	14 mil PE	Butyl rubber	adhesive			FI, ND, PB	P	31
Sample C	14 mil PE	Butyl rubber	adhesive			FI, ND, PB	P	31
Sample D	6 mil PE	Butyl rubber	backing			FI, ND, Sep	P	31
Sample D	6 mil PE	Butyl rubber	adhesive			FI, ND, PB	P	31

Note- None of the sealants tested reacted with the butyl rubber adhesive formulations. All of the sealants tested reacted with the SBS asphalt adhesive system that was tested.

Key:

LB - light surface bloom on backing
 MB - moderate surface bloom on backing
 HB - heavy surface bloom on backing
 N - no
 SL - slight
 M - moderate

Sep - can separate
 PB - permanently bonded
 H - heavy
 D - discoloration
 P - plasticized
 Br - brittle
 FI - flexible

Nashua®
TAPE PRODUCTS

626-20



NASHUA® 626-20
Optiflash F20 Window Flashing Tape

APPLICATIONS

- Window and Door Installations
- Corner Board Abutments
- Sidewall sheathing seams.
- Deck-to-wall Joints
- Sealing other detail areas against water and air penetration

FEATURES & BENEFITS

- Consists of a butyl-based adhesive which exhibits excellent adhesion to most building materials including plywood, OSB, housewrap, concrete, and most metals
- Provides long-term weather-tight seal to prevent moisture, vapor, and air penetration.
- Kraft paper release liner for ease of application.
- Resists UV degradation for 12+ years of direct sun exposure.
- Flexible at low temperatures; stays pliable to maintain a tight seal.
- Provides strong and immediate adhesion over a wide range of application temps (20°F-180°F)
- Compatible with sealants and caulking. Does not react with solvent-based solutions.
- Available in 4", 6" and 9"

CONSTRUCTION

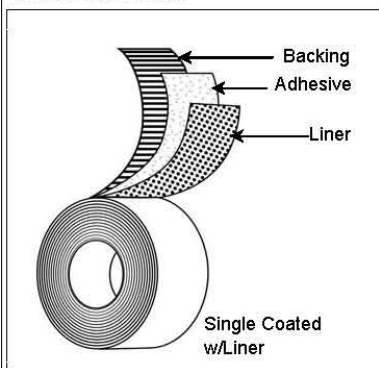

PRODUCT DESCRIPTION

Single-Coated w/Liner Construction

Backing:

- 2 mil Aluminum Foil

Adhesive:

- Butyl Rubber

Liner:

- Release-coated Kraft Paper

Colors:

- Aluminum

TEST DATA

Test	Typical Value	Typical Value (Metric)	Test Method
Total Thickness	20 mils	508.00 μ	ASTM D 1000
Backing Thickness	2 mils	50.80 μ	ASTM D 1000
Adhesive Thickness	18 mils	457.20 μ	ASTM D 1000
Adhesion Values			
Steel	18.3 lb./in.	3.20 N/mm	PSTC-1
Plywood	>6 lb./in.	1.05 N/mm	ASTM D903-9;
OSB	>4.8 lb./in.	0.8 N/mm	
Felt	>6.2 lb./in.	1.1 N/mm	
Unprimed Brick	>5.2 lb./in.	0.9 N/mm	
Housewrap	>14.5 lb./in.	2.5 N/mm	
Extruded Vinyl	>12.6 lb./in.	2.2 N/mm	
Tensile Strength (Machine)	800 psi	5512 kN/m2	ASTM D412-9
Tensile Strength (Cross)	800 psi	5512 kN/m2	ASTM D412-9
Application Temperature Range	20°F to 180°F	-7°C to 82°C	
Service Temperature Range	-35°F to 200°F	-37°C to 93°C	

* Rectangular specimen

** Test after 24 hour dwell time at 73° F and 50% humidity to p

The information presented herein was prepared at Berry Plastics, Tapes & Coatings Division (25 Forge Parkway Franklin, MA 02038) by qualified technical person. To Berry's knowledge it is true and accurate. However, the information and recommendations are furnished for these products with the understanding that the purchaser or user, as the case may be, will independently determine that the product is suitable for the intended use, and that such use complies with all applicable federal, state and local laws and regulations. The data are submitted only for the user's information and consideration, and do not constitute a warranty of any kind (including but not limited to a warranty of merchantability or of fitness for a particular purpose), or a representation for which BERRY PLASTICS assumes any legal responsibility.

POLYKEN® 626-35



POLYKEN® 626-35
Foilastic Premium Flashing Tape

APPLICATIONS

- Used to flash hip, ridge, and penetration details on concrete tile roofs.
- Gutters, roof valleys and eaves, chimneys and vents, rooftop duct systems.
- Sheet metal repairs on mobile homes, outdoor buildings, and trailers.
- Flash around window, door, skylight and dormer openings.
- Any above-grade critical areas that need protection against water and air leaks.

FEATURES & BENEFITS

- Provides an excellent bond to wood, metal, vinyl and other common building materials.
- Compatible with most caulking and sealants - does not react with most solvent-based solutions.
- Provides long-term weather-tight seal to prevent air, moisture, and water vapor penetration.
- Easy to remove blue LDPE release liner that will not tear.
- Paintable aluminum backing.
- Flexible at low temperatures & stays pliable to maintain a tight seal.
- No cracking over 1/4" at mandrel at 0°F.
- Protective aluminum backing allows for indefinite UV exposure.
- This product is covered by 12-year limited warranty. Please see warranty for details.

CONSTRUCTION

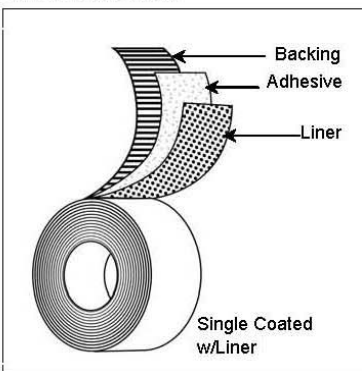

PRODUCT DESCRIPTION

Single-Coated w/Liner Construction

- Backing:**
- 2 mil Aluminum Foil
- Adhesive:**
- Butyl Rubber
- Liner:**
- Blue LDPE
- Colors:**
- Aluminum

TEST DATA

Test	Typical Value	Typical Value (Metric)	Test Method
Total Thickness	35 mils	889.00 µ	ASTM D 1000
Backing Thickness	2 mils	50.80 µ	ASTM D 1000
Mastic Thickness	33 mils	838.20 µ	ASTM D 1000
Adhesion Values			
Steel	18.3 lb./in.	3.20 N/mm	PSTC-1
Plywood	>12.3 lb./in.	2.1 N/mm	ASTM D903-93
OSB	>8.7 lb./in.	1.5 N/mm	
Felt	>11 lb./in.	1.9 N/mm	
Unprimed Brick	>7.3 lb./in.	1.3 N/mm	
Housewrap	>15.2 lb./in.	2.7 N/mm	
Extruded Vinyl	>14.9 lb./in.	2.6 N/mm	
Tensile Strength (Machine)	445 psi	3066 kN/m2	ASTM D412-97
Tensile Strength (Cross)	300 psi	2411 kN/m2	ASTM D412-97
Application Temperature Range	20°F to 180°F	-7°C to 82°C	
Service Temperature Range	-30°F to 200°F	-34°C to 93°C	

***Recommended storage conditions: 40-60% Humidity, 60°F-80°F (15°C - 20°C)
The information presented herein was prepared at Berry Plastics, Tapes & Coatings Division (25 Forge Parkway Franklin, MA 02038) by qualified technical personnel. Berry's knowledge is true and accurate. However, the information and recommendations are furnished for these products with the understanding that the purchaser in the case may be, will independently determine that the product is suitable for the intended use, and that such use complies with all applicable federal, state and local regulations. The data are submitted only for the user's information and consideration, and do not constitute a warranty of any kind (including but not limited to a warrant merchantability or of fitness for a particular purpose), or a representation for which BERRY PLASTICS assumes any legal responsibility.



627-20



NASHUA® 627-20
Optiflash B20 Window Flashing Tape

APPLICATIONS

- Window and Door Installations
- Corner Board Abutments
- Sidewall sheathing seams
- Deck-to-wall Joints
- Sealing other detail areas against water and air penetration

FEATURES & BENEFITS

- Consists of a butyl-based adhesive which exhibits excellent adhesion to most building materials including plywood, OSB, housewrap, concrete, and most metals.
- Provides long-term weather-tight seal to prevent moisture, vapor, and air penetration.
- Kraft paper release liner for ease of application.
- Resists UV degradation for up to 1 year of direct sun exposure.
- Flexible at low temperatures; stays pliable to maintain a tight seal.
- Provides strong and immediate adhesion over a wide range of application temps (20°F-180°F).
- Compatible with sealants and caulking. Does not react with solvent-based solutions.
- Available in 4", 6" and 9"

CONSTRUCTION

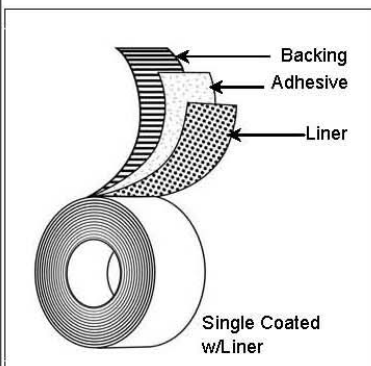

PRODUCT DESCRIPTION

Single-Coated w/Liner Construction

Backing:

- Polyethylene

Adhesive:

- Butyl Rubber

Liner:

- Release-coated Kraft Paper

Colors:

- Black

TEST DATA

Test	Typical Value	Typical Value (Metric)	Test Method
Total Thickness	20 mils	508.00 µ	ASTM D 1000
Backing Thickness	6 mils	152.40 µ	ASTM D 1000
Adhesive Thickness	14 mils	355.60 µ	ASTM D 1000
Adhesion Values			
Steel	16.8 lb./in.	2.90 N/mm	PSTC-1
Plywood	>3.91 lb./in.	0.68 N/mm	ASTM D903-9.
OSB	>4.0 lb./in.	0.7 N/mm	
Felt	>4.3 lb./in.	0.7 N/mm	
Unprimed Brick	>3.5 lb./in.	0.6 N/mm	
Housewrap	>13.1 lb./in.	2.3 N/mm	
Extruded Vinyl	>10.1 lb./in.	1.8 N/mm	
Tensile Strength (Machine)	1371 psi	9446 kN/m2	ASTM D412-9
Tensile Strength (Cross)	400 psi	2756 kN/m2	ASTM D412-9
Application Temperature Range	20°F to 180°F	-7°C to 82°C	
Service Temperature Range	-35°F to 200°F	-37°C to 93°C	

* Rectangular specimen

Recommended storage conditions: 40-60% Humidity, 60°F-80°F

The information presented herein was prepared at Berry Plastics, Tapes & Coatings Division (25 Forge Parkway Franklin, MA 02038) by qualified technical person. To Berry's knowledge it is true and accurate. However, the information and recommendations are furnished for these products with the understanding that the purchaser or user, as the case may be, will independently determine that the product is suitable for the intended use, and that such use complies with all applicable federal, state and local laws and regulations. The data are submitted only for the user's information and consideration, and do not constitute a warranty of any kind (including but not limited to a warranty of merchantability or of fitness for a particular purpose), or a representation for which BERRY PLASTICS assumes any legal responsibility.



25 Forge Parkway
Franklin, MA 02038
800-343-7875
www.berryplastics.com



POLYKEN® 627-35



POLYKEN® 627-35
Shadowlastic Premium Flashing Tape

APPLICATIONS

- Used under tile on the ridge and hip lines of roofs to prevent moisture from entering the building.
- Flash around window and door openings.
- Flash around skylights and dormers.
- Any above-grade critical areas that need protection against air and moisture penetration.

FEATURES & BENEFITS

- Provides an excellent bond to wood, metal, vinyl and other common building materials.
- Formulated for conformability in both warm and cold weather temperatures.
- Compatible with most caulking and sealants - does not react with most solvent-based solutions.
- Provides a long-term weather-tight seal to prevent air, moisture and water vapor penetration.
- Resists UV degradation for up to 1 year of direct exposure to sunlight.
- Easy to remove blue LDPE release liner that will not tear.
- This product is covered by 12-year limited warranty. Please see warranty for details.

CONSTRUCTION

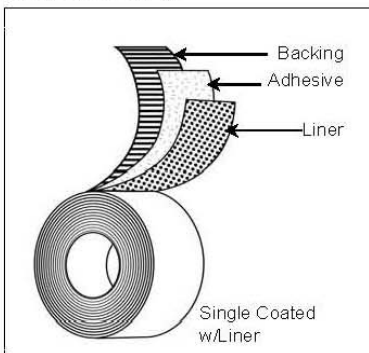

PRODUCT DESCRIPTION

Single-Coated w/Liner Construction

Backing:
• Polyethylene

Adhesive:
• Butyl Rubber

Liner:
• Blue LDPE

Colors:
• Black

TEST DATA

Test	Typical Value	Typical Value (Metric)	Test Method
Total Thickness	35 mils	889.00 µ	ASTM D 1000
Backing Thickness	6 mils	152.40 µ	ASTM D 1000
Mastic Thickness	29 mils	736.60 µ	ASTM D 1000
Adhesion Values			
Steel	17.6 lb./in.	3.10 N/mm	PSTC-1
Plywood	>8.8 lb./in.	1.5 N/mm	ASTM D903-93
OSB	>7.8 lb./in.	1.4 N/mm	
Felt	>9.4 lb./in.	1.6 N/mm	
Unprimed Brick	>9.4 lb./in.	1.6 N/mm	
Housewrap	>13.9 lb./in.	2.4 N/mm	
Extruded Vinyl	>14.8 lb./in.	2.6 N/mm	
Tensile Strength (Machine)	813 psi	5602 kN/m ²	ASTM D412-97
Tensile Strength (Cross)	300 psi	2411 kN/m ²	ASTM D412-97
Application Temperature Range	20°F to 180°F	-7°C to 82°C	
Service Temperature Range	-30°F to 200°F	-34°C to 93°C	

**Recommended storage conditions: 40-60% Humidity, 60°F-80°F

The information presented here in was prepared at Berry Plastics, Tapes & Coatings Division (25 Forge Parkway, Franklin, MA 02038) by qualified technical personnel. To Berry's knowledge it is true and accurate. However, the information and recommendations are furnished for these products with the understanding that the purchaser or user, as the case may be, will independently determine that the product is suitable for the intended use, and that such use complies with all applicable federal, state and local laws and regulations. The data are submitted only for the user's information and consideration, and do not constitute a warranty of any kind (including but not limited to a warranty of merchantability or of fitness for a particular purpose), or a representation for which BERRY PLASTICS assumes any legal responsibility.

Nashua®
TAPE PRODUCTS

Contour



NASHUA® Contour
Stretchable Window Flashing Tape

APPLICATIONS

- Excellent for flashing around window sills, interior corners of recessed windows, round top windows, and arched doorways
- Eliminates the need for corner flashing patches at window sides
- Any above-grade critical areas that need protection against air and moisture penetration

FEATURES & BENEFITS

- Consists of a butyl-based adhesive which exhibits excellent adhesion to most building materials including plywood, OSB, housewrap, concrete and most metals.
- Wide application temperature range (20° to 180°F).
- Provides a long-term weather-tight seal to prevent air, moisture, and vapor penetration.
- UV inhibitors prevent degradation for up to 1 year of direct exposure to the sun.
- Exceptional moisture resistance.
- Conforms easily to curved surfaces - forms a permanent watertight/airtight seal.
- An all-weather flashing tape - remains flexible and adheres in cold temperatures
- Available in 6" & 8" widths.

CONSTRUCTION

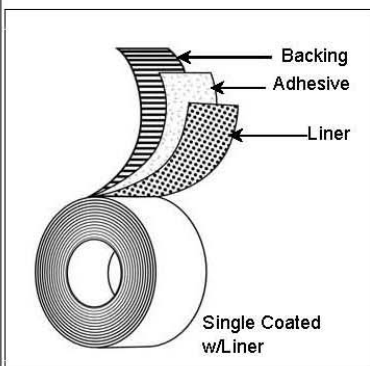

PRODUCT DESCRIPTION

Single-Coated w/Liner Construction

- Backing:**
- Creped, cross-laminated Polyolefin Film
- Adhesive:**
- Butyl Rubber
- Liner:**
- Polyethylene
- Colors:**
- White

TEST DATA

Test	Typical Value	Typical Value (Metric)	Test Method
Total Thickness	60 mils	1524.00 µ	ASTM D 1000
Adhesion Values			
Steel	>7.1 lb./in.	1.20 N/mm	PSTC-1
Plywood	>6 lb./in.	1.05 N/mm	ASTM D903-9:
OSB	>6.3 lb./in.	1.1 N/mm	
Felt	>7.4 lb./in.	1.3 N/mm	
Unprimed Brick	>7.4 lb./in.	1.3 N/mm	
Housewrap	>9.4 lb./in.	1.6 N/mm	
Extruded Vinyl	>8.7 lb./in.	1.5 N/mm	
Tensile Strength (Machine)	>295 psi	2033 kN/m2	ASTM D412-9*
Tensile Strength (Cross)	>400 psi	2756 kN/m2	ASTM D412-9*
Application Temperature Range	20°F to 180°F	-7°C to 82°C	
Service Temperature Range	-30°F to 200°F	-34°C to 93°C	

* Rectangular specimen

** Test after 24 hour dwell time at 73°F and 50% humidity to plywood

Recommended storage conditions: 40-60% Humidity, 60°F-80°F

The information presented herein was prepared at Berry Plastics, Tapes & Coatings Division (25 Forge Parkway Franklin, MA 02036) by qualified technical personnel. To Berry's knowledge it is true and accurate. However, the information and recommendations are furnished for these products with the understanding that the purchaser or user, as the case may be, will independently determine that the product is suitable for the intended use, and that such use complies with all applicable federal, state and local laws and regulations. The data are submitted only for the user's information and consideration, and do not constitute a warranty of any kind (including but not limited to a warranty of merchantability or of fitness for a particular purpose), or a representation for which BERRY PLASTICS assumes any legal responsibility.

POLYKEN®**1027**

POLYKEN® 1027
Primer/Liquid Adhesive System

APPLICATIONS

- Surface preparation for masonry, concrete, OSB, rigid insulation, wood and metal.
- Brush or roller priming applications.
- Provides a uniformly smooth, instant-tack surface to promote adhesion and long term anchorage.

FEATURES & BENEFITS

- Non-toxic, non-polluting.
- Conforms to local and national standards.
- Dries to a uniform, smooth finish to provide a superior bonding surface for butyl-based flashing tapes.
- Easy to apply, no over-spray.

Product Basics

Polyken® liquid adhesive systems are recommended for use with Polyker® and Nashua® window, door, and roof flashing products. The liquid adhesive system consists of butyl based elastomers blended with polymeric resins dissolved in an organic solvent system. They can be used for hand, brush, or roller application are non-toxic, non-polluting, and conform to local and national standards

Base:	Rubber/Resins
Solvent:	V.M. & P Naptha
Total Solids:	30%
Weight/Gallon:	7.1 lb
Weight/Liter:	.86 kg

Physical Characteristics

Property	Value
Viscosity	Medium Syrup
Flash Point	+40°F (4°C)
Color	Black
Shelf Life	Excellent
VOC	4.9 lbs/gal (0.59 kg/l)
Coverage Rate	4 Sq/Gal (9.8 m²/l)

Warning: Polyken® liquid adhesive systems are FLAMMABLE MIXTURES.

Caution: Store away from heat source. Read all label instructions prior to use.

***Recommended storage conditions: 40-60% Humidity, 60°F-80°F (15°C - 20°C)

The information presented herein was prepared at Berry Plastics, Tapes & Coatings Division (25 Forge Parkway Franklin, MA 02038) by qualified technical personnel. Berry's knowledge is true and accurate. However, the information and recommendations are furnished for these products with the understanding that the purchaser in the case may be, will independently determine that the product is suitable for the intended use, and that such use complies with all applicable federal, state and local regulations. The data are submitted only for the user's information and consideration, and do not constitute a warranty of any kind (including but not limited to a warranty of merchantability or of fitness for a particular purpose), or a representation for which BERRY PLASTICS assumes any legal responsibility.